

Exercises from “The RF in RFID”

Chapter 2

1. Can a passive RFID tag be read from a satellite? _____ YES X NO

Inductively-coupled (LF or HF) tags can be read from a distance comparable to the size of the reader antenna. UHF passive tags can be read from a few meters away. In order to power a passive tag from a couple hundred kilometers in the air, a satellite would a very large antenna (tens of meters) and thousands of kiloWatts of RF power – possible in principle but very, very expensive. And then you’d need to detect a tiny tag signal, requiring a separate, well-isolated, very expensive antenna still pointed at the same location. Spectacularly impractical. The underlying reasons for these ranges are explained in more detail in chapter 3.

2. Can a 125 kHz tag be read from across a street? _____ YES X NO

Inductively-coupled tags are generally readable over a range comparable to the antenna size. Assuming an ordinary antenna, typically 10-50 cm in diameter, it would be very difficult to read a passive 125 kHz tag from 10 meters away.

3. If you swallow a passive UHF RFID tag, the consequences will include:
- a. The tag will be read by a reader with antenna placed on your stomach
 - b. The tag will be read by a reader up to 3 meters away
 - c. The tag will be unreadable due to reflection and absorption by water
 - d. You will have a seriously upset stomach
- (list all that apply): _____

The correct answers are c and d (the latter depending on the tag type and encapsulation). A water interface reflects much of the incident power away, and significant absorption will also occur within the body (which is somewhat like a weak salt solution); finally, immersion of the tag in an aqueous environment seriously changes the antenna behavior and thus reduces power coupled to the integrated circuit.

Some folks have reported reading passive UHF tags in a small beaker of water from 10 cm away [US patent application 2006/0289640, Mercure et. al.] but I haven’t been able to reproduce their result; such a read could certainly not be conducted with existing equipment from 3 meters.

4. Is your cellphone likely to interfere with a High-Frequency (13.56 MHz) reader mounted 3 meters from your desk? _____ YES X NO

Cellular phones in the US transmit in the 824-849 MHz band (or PCS at around 2 GHz); in Europe they use GSM 900 band, 890-915 MHz. These frequencies are unlikely to bother a 13.56 MHz reader.

5. How often do you need to change the battery on an Alien ‘squiggle’ tag?
a. Once a month
b. Once a year
c. Every 5 years
d. What battery?

(d) is the correct answer. The squiggle is a passive tag and doesn’t have a battery.

6. Can an EPCGlobal class-0-only reader read a class 1 tag? X YES X NO

Class 0 and Class 1 are incompatible in every respect except the reader physical-layer symbols; more about that in chapter 8.

7. How many unique identifying codes are possible using 96 bits? [If you don’t have a calculator available, a hint: $\log_2 10 \approx 3.32$] : $2^{96} \approx 7.9 \times 10^{28}$

“A lot” is a perfectly acceptable answer.

8. Do all RFID readers need an antenna? X YES _____ NO

There had to be one question with a YES answer. Since by definition RFID refers to the use of radio to communicate identifying data, there must be some sort of device that converts electronic signals to electromagnetic fields – an antenna.

9. If you can’t read a specific UHF passive tag 2 meters from a reader antenna, will it continue to be invisible to the reader at any distance larger than 2 meters? _____ YES X NO

Propagation is complicated in indoor environments with lots of stuff for the waves to bounce off of. You can have a dead spot at 2 meters where a UHF tag fails to read, move it 30 or 40 cm farther from the reader and have it re-appear and read very consistently.

Chapter 3

Frequency and wavelength:

1. RFID operation worldwide extends from about 860 MHz to 960 MHz. Find the corresponding wavelength in meters. Use c (speed of light) = 3×10^8 meters/second.

0.35 m at 860 0.31 m at 960

Wavelength = velocity / frequency.

2. A typical commercial tag might have an antenna that is 9.5 cm long. How big a fraction of the wavelength is this at 860 MHz? 960 MHz?

0.27 at 860 0.30 at 960

That is, typical tags are notably shorter than a half-wavelength, so they are considered to be electrically short antennas.

Voltage and power, path loss:

3. FCC regulations allow a reader to transmit 1 watt. What is the power in dBm?
30 dBm

1 Watt is 1000 milliwatts, and the power in dBm is thus 10 times the base-10 logarithm of 1000 (30).

4. A tag receives 20 microwatts of power from a 1-watt reader. What is the path loss in dB?

47 dB

The path loss is the ratio of the transmitted and the received power; when expressed in dB, it's just the difference between the powers in dBm. Thus here it is $(30 - (-17))$ dB, where 30 dBm is the transmit power (1 W) and -17 dBm is the received power (20 microwatts).

5. Assume the reader in problem (2) above uses a perfect isotropic antenna and the tag antenna has an effective area of 50 square centimeters. What is the tag-reader distance?

4.5 meters

If the reader antenna is isotropic, the transmitted power (1 W) is spread uniformly over the surface of a sphere r meters in diameter. A fraction of this

power $0.005/A$ (in square meters) is collected by the antenna. The collected power is thus the transmitted power multiplied by the ratio of the effective aperture of the antenna, 0.005 , and the area of the sphere, $4\pi r^2$. When this ratio is equal to -47 dB (about 2×10^{-5}) the collected power is 20 microwatts, as desired.

6. Let's give the reader a directional antenna. Assume the gain of the reader antenna is 6 dBi, and that of the tag antenna is 1.5 dBi. How much power does the tag receive at the distance you found in problem (3) above, assuming a frequency of 924 MHz? What is the EIRP of the reader?

185 microwatts -7.3 dBm EIRP: 36 dBm

The power is most conveniently obtained in this case from the Friis equation (3.20). The transmitted power is 1 W; the transmit gain is 4 (i.e., $10^{0.6}$), the received gain is about $10^{0.15} \approx 1.4$, and the wavelength is roughly 0.325 m. Inserting these into (3.20) we obtain the received power, which can be re-expressed in dBm. The effective isotropic radiated power is just the transmit power multiplied by the gain of the antenna, or the sum of the logarithmic quantities: 30 dBm + 6 dBm = 36 dBm.

Chapter 4:

RFID configurations:

1. How many antennas are used simultaneously for transmit and receive functions in a monostatic RFID reader?

1 See definition of the term, Figure 4.1.

2. A bistatic antenna provides 45 dB of isolation from transmit to receive, and is used with a 1/2-watt transmitter. How much transmit power leaks into the receiver?

-18 dBm = 27 dBm (transmit power) – 45 dB (isolation).

Radio architectures:

3. A superheterodyne receiver (commonly used for conventional radio receivers, though not typical for RFID equipment) uses a local oscillator frequency of 800 MHz to receive a signal at 867 MHz. What is the intermediate frequency (IF)? What is the image frequency?

IF: 67 MHz image: 733 MHz

The IF is the difference between the local oscillator frequency and the signal frequency. The image frequency is (in this case) 67 MHz below the LO, when the wanted frequency is 67 MHz ABOVE the LO.

4. A direct conversion RFID receiver is intended to successfully receive a tag signal as small as –65 dBm, with a resulting output voltage swing of 0.5 V to drive a comparator with a 300-ohm input resistance. What is the overall gain of the receiver? What voltage would be produced by a –10 dBm input signal?

Gain: 55 dB interferer output: 141 volts

If we treat the term “voltage swing” as describing the peak-to-peak output, the amplitude of the signal is 0.25 V, so the power into a 300 ohm resistor is about -10 dBm (0.1 mW) using equation (3.3). Thus 55 dB of gain is needed to raise the wanted minimum signal to this level. Using the same gain, an interfering signal would produce an output power of 45 dBm (33 W), which corresponds to around 141 volts into a 300-ohm resistor. Ouch! The point is, of course, that something would saturate long before we got to such voltage

levels: an interferer this big has to be removed somehow in the radio chain or it will overwhelm the wanted signal.

Radio components:

5. An amplifier has a gain of 14 dB. An input signal of -10 dBm causes the amplifier to suffer 1 dB of gain compression. What is P1dB?

P1dB: 3 dBm

The uncompressed gain is 14 dB, so at the compression point the gain is 13 dB. Thus the output power when the gain is compressed by 1 dB (which is P1dB) is $-10 \text{ dBm} + 13 \text{ dB} = 3 \text{ dBm}$.

6. An RFID receiver operating at 906.5 MHz is also illuminated by two other nearby readers operating at 909 and 912.5 MHz. What spurious frequencies might be produced in the receiver by third-order distortion? Are they likely to interfere with the tag signal at 906.5 MHz?

low spur: 905.5 MHz high spur: 916 MHz
interference concern?: yes X no

The third-order intermodulation products we are usually concerned with from a two-tone input are $(2f_1-f_2)=905.5$ and $(2f_2-f_1)=916$. The third-harmonic terms are generally easy to filter and can be ignored (here they would be at around 2.7 GHz). The high spur is far from the wanted signal and readily filtered. The low signal is 1 MHz from the wanted signal and still usually ok; recall that RFID tag signals usually only contain frequencies up to a few hundred kHz, so we can use a baseband filter that cuts out 1 MHz signals. However, if we were trying to get e.g. high-rate Gen 2 tags running at 640 kbps (see chapter 8) it might be tough to remove a large interfering signal 1 MHz from the wanted signal.

7. The reader signals in problem (6) above are both at -15 dBm, at the input into a mixer with an input third-order intercept of 5 dBm. (Here we are defining the intercept as the power at which a spurious output tone is equal to the power of one of the two input tones.) The wanted signal (the one you're trying to hear) is at -50 dBm at the mixer. What is the level of the output spurious tones from the mixer relative to the wanted signal?

spurious power: -40 dBc

We're backed off by 20 dB from the intercept, so the output spurs are suppressed by 40 dB relative to the linear output – that is, the answer is -40 dBc.

8. A special low-rate, long-range RFID tag can be received by a receiver using only 10 KHz of bandwidth. The room-temperature receiver uses an amplifier with a noise figure of 4 dB, and enough gain so that other sources of noise in the receiver are negligible. What is the smallest signal that can be detected, if a signal:noise ratio of 12 dB is needed?

minimum detectable signal: _____ dBm

The noise power in 10 kHz is $-174 \text{ dBm/Hz} + 40 \text{ dB} = -134 \text{ dBm}$. The equivalent input noise for the amplifier is obtained by adding the noise figure to the true input noise, so $-134 + 4 = -130 \text{ dBm}$. The signal must be 12 dB above this noise level, or -118 dBm . This is indeed a long-range tag if it is reverse-link-limited – a 1 watt reader would achieve around 180 meter range (see equation (3.23)).

9. A mixer is used to detect the tag signal in problem (8) above. Both the tag signal and the local oscillator are at the same frequency, 905 MHz. What are the frequencies of the two output signals from the mixer? Does either signal depend on the absolute phase difference between the tag signal and the LO?

low output: _____ MHz high output: _____ MHz

The low-frequency output is the difference between 905 and 905, that is, 0 (though of course when the tag is modulating its reflection, higher-frequency components will be present). The high-frequency output is the sum of the the LO and the RF signal. The 0-Hz signal output voltage is dependent on the absolute phase of the LO and RF signals; see Figure 4.18.

10. A local oscillator employs an inductor of 15 nanoHenries (nH) in the resonant feedback circuit. What value of tuning capacitance (picoFarads, pF) must be used to make the oscillator operate at 915 MHz?

C_{res} : _____ pF

The resonant frequency is $\omega^2 = 1/LC$ where $\omega=2\pi f$ is the angular frequency, so $C = 1/\omega^2 L$.

11. The local oscillator above is connected to a phase-locked loop, with a compare frequency of 500 KHz. What value of the divisor, N, is needed to produce the requisite 915 MHz output?

N: 1830 = $915 \times 10^6 / 500,000$.

12. What filter bandwidth is needed to accept the European (ETSI) RFID band at 865-869 MHz? Is such a filter narrower or broader than a filter designed to accept the US ISM band (902-928 MHz)?

bandwidth: 0.5 % vs. US ISM: narrower

The percent bandwidth is the bandwidth in MHz divided by the center frequency: $4 \text{ MHz} / 867 \text{ MHz} = 0.5\%$. The US ISM band (902-928 MHz) is 2.8% wide, so the ETSI band is much narrower both in absolute and relative terms.

13. An analog-to-digital converter with a maximum input of 1 volt and a resolution of 8 bits is used to digitize the output of an RFID receiver. What is the smallest change in input voltage that can be resolved, neglecting any analog noise in the system?

minimum resolvable signal: 0.004 V

Roughly speaking, there are 256 levels (2^8) spanning 0 to 1 V input, so the smallest signal that is guaranteed to increment the output by 1 is $1/256 \approx 0.004 \text{ V}$. (OK, the input could have been differential – that is, from -1 V to 1 V -- in which case the answer here would increase by 2x).

RFID Transmitters:

14. A transmitter uses a simple switch to turn the signal on or off. Is the output spectrum wider than that of a more elaborate transmitter that uses a filter to smooth the output signal?

X yes ___ no

Abrupt signal transitions contribute more high-frequency spectral components than filtered signals do. See Figure 3.10.

15. A receiver is used to capture the output of an RFID transmitter. Upon careful examination, we find that the positive peaks of the RF signal from the (RF-on) part of a symbol occur at the times we would have expected a negative peak based on the previous symbol. What modulation scheme is probably being used?

amplitude-shift keying (ASK) ___ phase-reversal ASK X
single-sideband (SSB) ___

If the positive RF peak in one symbol is where we would have expected a negative peak based on the timing of the previous symbol, the phase of the signal has changed by 180° (π radians). Simple ASK produces no consistent phase change between successive symbols. Single-sideband with the carrier present also produces no change between successive RF-high portions (and if the carrier is not present, a tag can't hear the modulation, since it would then be a constant-envelope signal). PR-ASK is specifically designed to include a phase change of 180° between successive symbols to reduce the signal bandwidth while remaining envelope-detectable.

16. A monostatic RFID reader is connected by a 1-meter cable to the antenna. By measurement it is found that the phase noise-amplitude noise conversion efficiency is -40 dB. The antenna is then moved farther away from the reader, so that a 10-meter (low loss!) cable replaces the 1-meter cable. What is the worst-case effect on the phase noise conversion?

phase-amplitude noise increased by: 20 dB

*The delay in the line is increased by a factor of 10, so the voltage in the delay line discriminator is increased by a factor of 10 (see equation (4.39)) and the power by a factor of 100, **assuming that the system was at a null in the first place**. (Recall that the worst case for phase noise conversion is when the reflected signal and transmitted signal are in quadrature, so the mixed output is on average = 0, but changes in frequency make it finite and thus convert phase noise to amplitude noise.)*

RFID Receivers:

17. To save money and time, Bob the lazy RF designer¹ constructs an RFID receiver with only a single branch (which we will call the in-phase or I branch). He calls his managers into the lab and demonstrates the ability to read a tag reliably when the tag is 240 cm from the reader antenna, using a fixed frequency of 915 MHz for the demo. How can dedicated designer Amy, witnessing the demo, embarrass her rival and get him fired?

 rotate the tag around its axis

 move the tag 16 cm farther from the antenna

 move the tag 8 cm closer to the antenna

 X remove the tag completely and show that it is still being read, since she saw Bob setting up software that fakes reads the previous night.

¹ it will be understood that this is a purely theoretical construct; all real RF designers work so hard that the author is sweating just thinking about it.

Rotating the tag around its axis may affect the result but will do so without obvious regard for how many channels there are. Moving the tag 16 cm takes it $\frac{1}{2}$ wavelength farther away: since the signal travels to the tag and then back, the total added pathlength is 1 wavelength and there is no effect on the phase. Moving the tag 8 cm ($\frac{1}{4}$ wavelength) will increase the path length by $\frac{1}{2}$ a wave and thus invert the phase of the reflected signal; it will still be picked up by the I branch. (A displacement of 4 cm would induce a 90° phase shift and make the tag disappear – but it's much better to show that Bob's faking the result!)

18. Bob also neglected to provide a blocking capacitor between the mixer output and the rest of his receiver, but got lucky in the first demo as the phase of the reflected signal from the antenna happened to be in quadrature with the local oscillator signal and generate no offset voltage. Amy saw the schematic lying on Bob's desk and noted the omission. While the managers are distracted by Blackberry messages regarding SEC investigations of their stock options, she changes out the antenna cable for one slightly longer. How much length does she need to add to put the reflected signal in phase with the LO and swamp the receiver with a huge DC offset, so that no tags can be detected even with valid software? (Assume the propagation velocity of signals on the cable is 60% of that of light in vacuum.)

2.5 cm

She needs to make the cable longer by $\frac{1}{8}$ of a wavelength, so that the reflected signal (which sees this extra distance on the way out and the way back) is offset by one quarter of a wave or 90° . The wavelength in the cable is about $(32.8 \times 0.6) = 19.7$ cm, so $\frac{1}{8}$ of a wave is 2.46 cm. Naturally, one can add any integral number of wavelengths to this answer and get the same result, e.g. $19.7 + 2.46 \approx 22.1$ cm, etc. (but bigger changes must be done very accurately!).

19. Will Bob realize the error of his ways after losing his job, and actually read this book (which has been sitting on his shelf unopened for several months), or will he become a physical therapist at a Sudoku-addiction treatment clinic? Which path is more likely to provide a lucrative future career?

*Clearly, he will do neither, but instead become a fabulously wealthy hedge fund manager after consuming a vial of Felix Felicis (see chapter 14 of **Harry Potter and the Half-Blood Prince**) purchased for US\$125 from a Harry Potter fan site. The vial, of course, contained distilled water.*

Chapter 5

Rectifiers:

1. We treated a diode as a very simple object that has no current flow until the voltage exceeds $+V_{ON}$, and unlimited current flow with no additional voltage thereafter. Real diodes are somewhat more accurately represented by equation (5.1), repeated here for convenience:

$$I = I_0 \left(e^{\frac{qV}{kT}} - 1 \right)$$

where the product q/kT is about 38.5 at room temperature. Let $I_0=10^{-15}$ A. What voltage across the diode will produce a diode current $I = 1$ microamp? What voltage is needed to achieve a diode current $I= 10$ mA? What error in voltage have we made by using an on-voltage of 0.5 V?

V(1 μ A): 0.54 Error vs. V_{ON} : 0.04

V(10 mA): 0.78 Error vs. V_{ON} : 0.28

2. We examined the use of voltage doublers to increase the output voltage of the rectifier stages. An alternative approach is to employ a *full-wave rectifier* circuit. A possible equivalent circuit for a full-wave rectifier attached to an antenna and load is shown below. Using the idealized diode model of Figure 5.3, find the output voltage for a given input voltage. Compare it to the output voltage of a doubler (equation (5.6)).

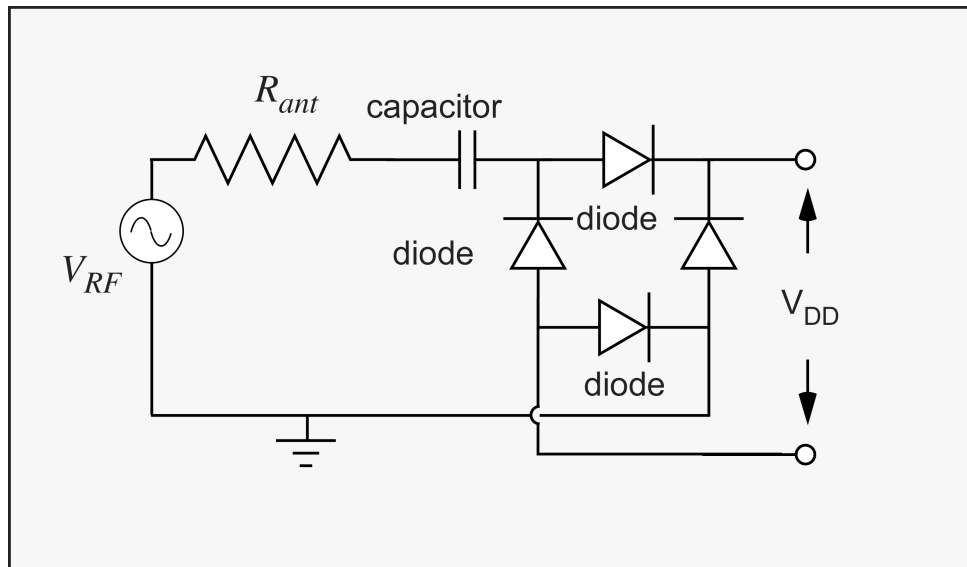

The situation at the positive and negative peaks of the input voltage is shown below. The peak output voltage is $V_{RF} - 2V_{on}$ in both cases, assuming that the blocking capacitor is big enough so that its impedance is small compared to R_{ant} . This would also be the DC output if we added a filter capacitor and the current drawn is negligible. The full-wave rectifier does not double the input voltage, but has the advantage that the signal has a path to the output during the full RF cycle (hence its name), so it is better at supplying output current. Note that if the load resistance is comparable to the antenna resistance, the output voltage will be reduced due to voltage drops across the antenna resistance.

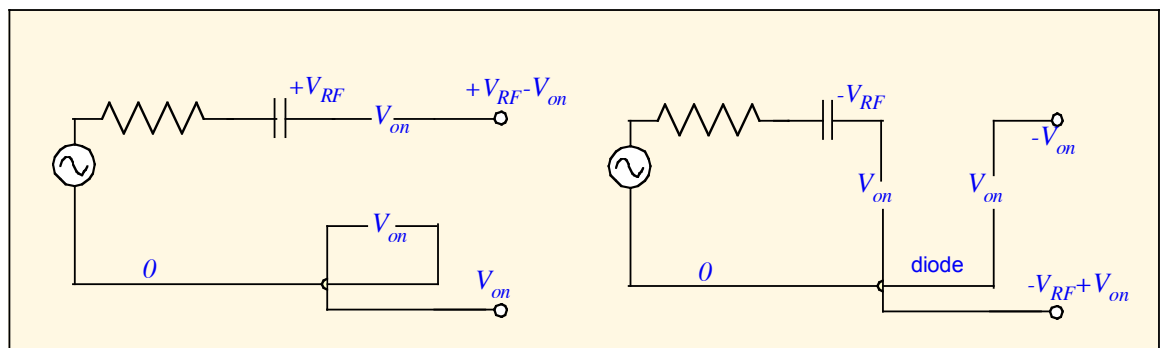

Backscatter modulation:

- An alternative way of imposing a modulation on a tag antenna is shown below. Assume that the radiation resistance and load resistance are both 100 ohms, and that the circuit is operated at 915 MHz. Let the modulation capacitor value be 1 pF. Find the complex impedance of the circuit in the modulated state (when the capacitor is **not** shorted out). Appendix 3 may be helpful. What is the magnitude of the current that flows through the circuit when the capacitor is present compared to that when the capacitor is shorted? What is the relative phase?

0.75 magnitude 41° (.72 radians) phase

The circuit impedance when the capacitor is present (that is, when the switch is open) is $Z = R_{rad} + R_{load} + 1/j\omega C_{mod}$. When the capacitor is shorted it is $Z = R_{rad} + R_{load}$. A 1 pF capacitor presents a reactance of about 174 ohms at 915 MHz. The complex impedance in this case is about $200 - j174$ ohms in the modulated state, which has a magnitude of about 265 ohms and a phase of about -41 degrees. So the current is $(200/265) \approx 0.75$, and the phase is 41 degrees.

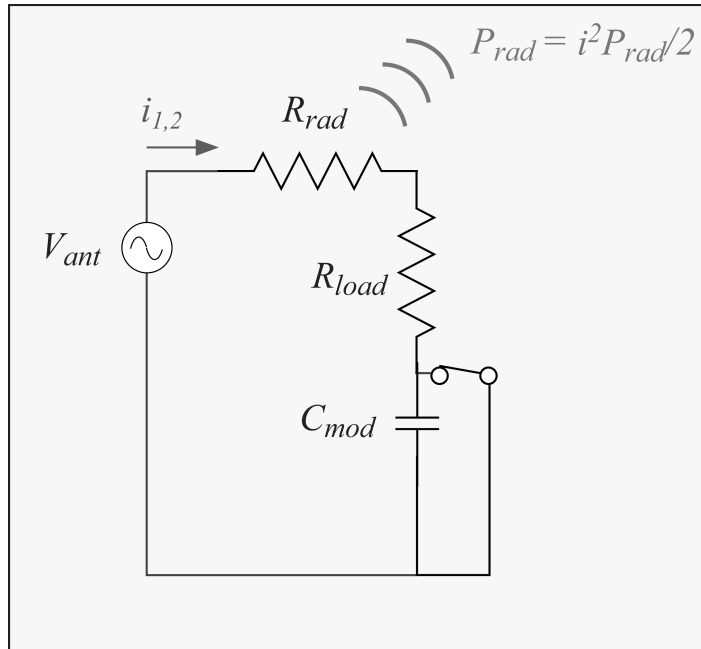

Find the power absorbed in the load in the modulated state as a fraction of the available power P_{av} .

0.57

The available power is just that present in the unmodulated state, $\frac{1}{2} I_{unmod}^2 R_{load}$. The power in the modulated state is $\frac{1}{2} I_{mod}^2 R_{load}$. The ratio of powers is just the square of the ratio of currents, which we obtained above.

Find the average load power, normalized to the available power, assuming the modulation occupies the two possible states with equal probability.

0.78 P_{av}

This is just $\frac{1}{2}(1+0.57)P_{av}$: the average of the power in the unmodulated and modulated states.

Subtract the complex value of the current through the radiation resistance when the capacitor is present from the current amplitude when the capacitor is shorted to find the change in current due to modulation. Find the absolute magnitude of this current, and square it and multiply by $R_{\text{rad}}/2$ to find the peak radiated power.

0.25 V_{ant}^2 (mW) or 0.22 P_{av} peak radiated power

For a unit antenna voltage, the modulated current is about $2.8 + j(2.5)$ in mA, whereas the unmodulated current (corresponding to P_{av}) is about 5 mA and is, of course, pure real. The difference is $-2.2 + j(2.5)$ mA, with magnitude 3.3 mA. The radiated power corresponds to half the power associated with this current (since the antenna spends half the time in the modulated state) so the radiated power is about .25 mW for unit antenna voltage. The available power is around 1.2 mW for unit antenna voltage, so the radiated power is around 1/5 of the available power.

(The average radiated power of an OOK signal is half this value.)

Divide by the available power to find the modulation efficiency:

0.2 modulation efficiency

One could also argue that the radiated power ought to be the power in the sidebands only. This implicitly defines the modulation as PSK in all cases, and changes the value of the signal-to-noise ratio needed to demodulate. I have tried to treat the problem consistently as amplitude-shift keying with average radiated power in the book, but this is not the only approach.

Chapter 6

Gain and read zone:

1. Consider the two-element array shown below:

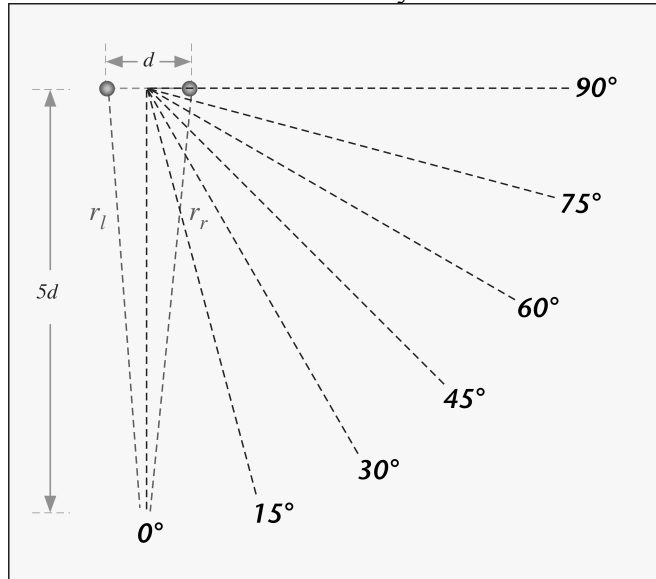

Treating $5d$ as equal to ∞ (and if you can do this without a second thought, you have a future in politics), measure the distances r_l and r_r from the two array elements to the end of the inclined dotted lines shown in the figure and record them, and their difference, below. (Use a ruler on paper, or use the digital version of the figure on the CD.)

Below is the table in mm actual size on the original figure; $d \approx 19.5$ mm:

Angle	r_l	r_r	$\delta = (r_l - r_r)/d$
0°	98.5	98.4	0.005
15°	95.6	100.7	-0.26
30°	93	102.6	-0.49
45°	91.3	104.9	-0.70
60°	89.3	105.9	-0.86
75°	88.1	106.9	-0.97
90°	87.6	107.2	-1.01

Now assume d is two thirds of a wavelength. The phase associated with $2/3$ of a wavelength is $(720/3)=240$ degrees. The difference in phase between the waves received from the left and right array elements is thus $\phi = 240 \delta$ in degrees.

For each case above, calculate this offset angle. Draw two arrows of equal length, one horizontal and one rotated by the angle ϕ . Considering them as edges of a parallelogram, construct the diagonal and measure its length relative to the

length of the original arrows. An example is shown below for the case of $\phi = 45^\circ$. This length is the received electric field due to the two array elements, relative to the field from a single element. It is equal to 2 for an angle of 0 degrees, so divide the length by 2 to get the antenna pattern relative to the maximum.

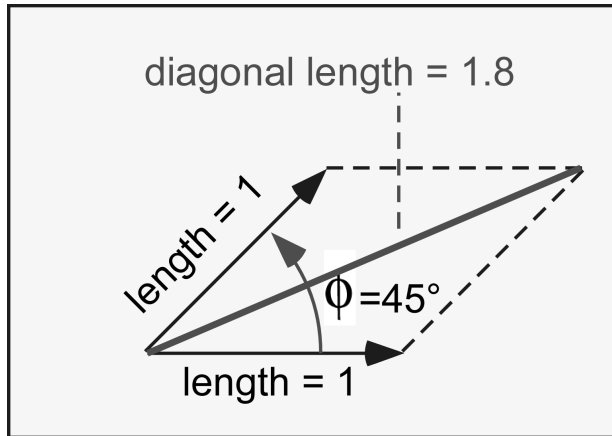

Using your results, plot the electric field pattern of the array on a graph like that shown below. (This is an H-plane slice of the pattern. What does the H-plane slice look like for a single dipole?)

Here's the answer for the measurements above.

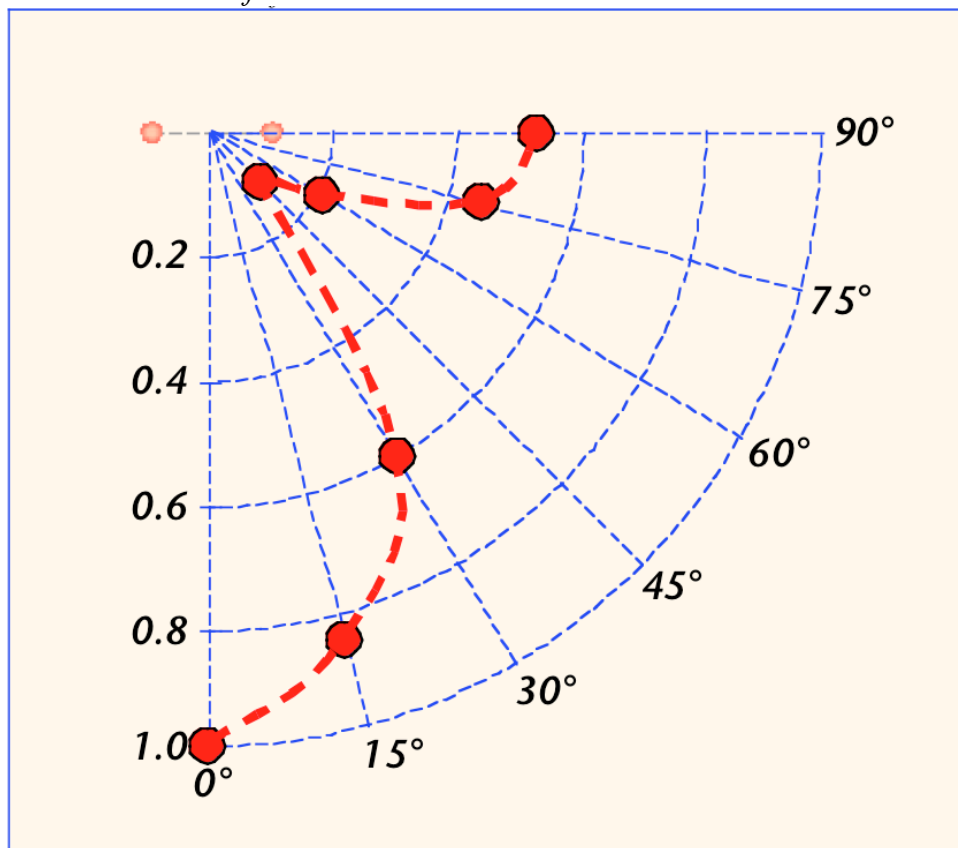

You can see that there's a null in the pattern. This occurs when the distances to the two array elements differ by half a wavelength (i.e. when $\delta=0.75$), as in that case the signals from the two elements arrive exactly 180° out of phase and cancel. So this array transmits mainly in the broadside direction; the endfire electric field (along the array axis) is reduced by about a factor of 2.

If you're feeling ambitious, also plot the square of the diagonal length, which corresponds to the relative received power.

2. Consider the antenna pattern given below for an ideal patch antenna:

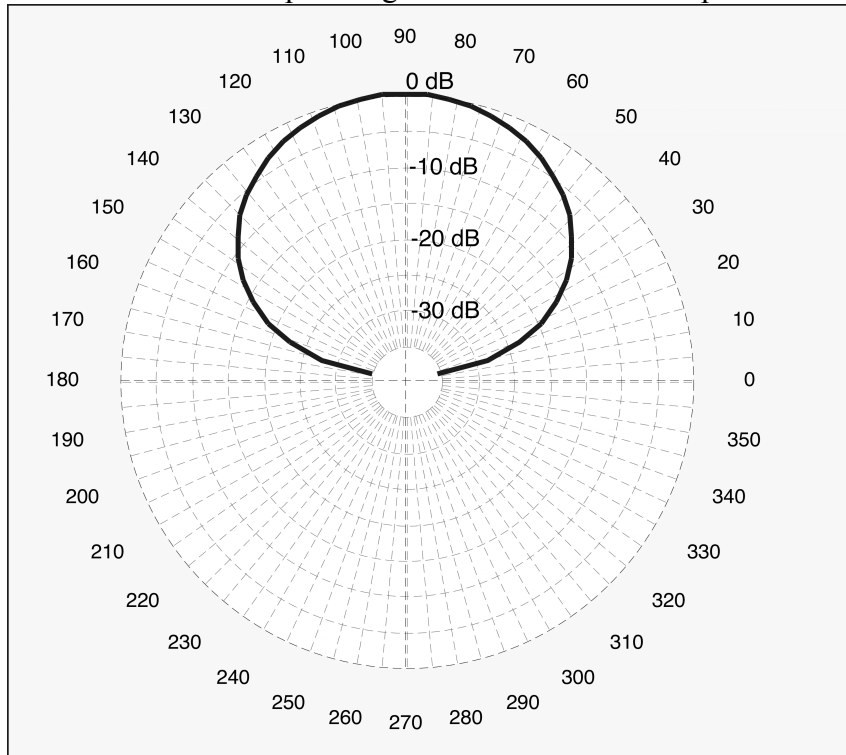

Extract the 3-dB and 6-dB beamwidth. *The 3-dB beamwidth is about 65° and the 6-dB beamwidth is about 90° , as shown below.*

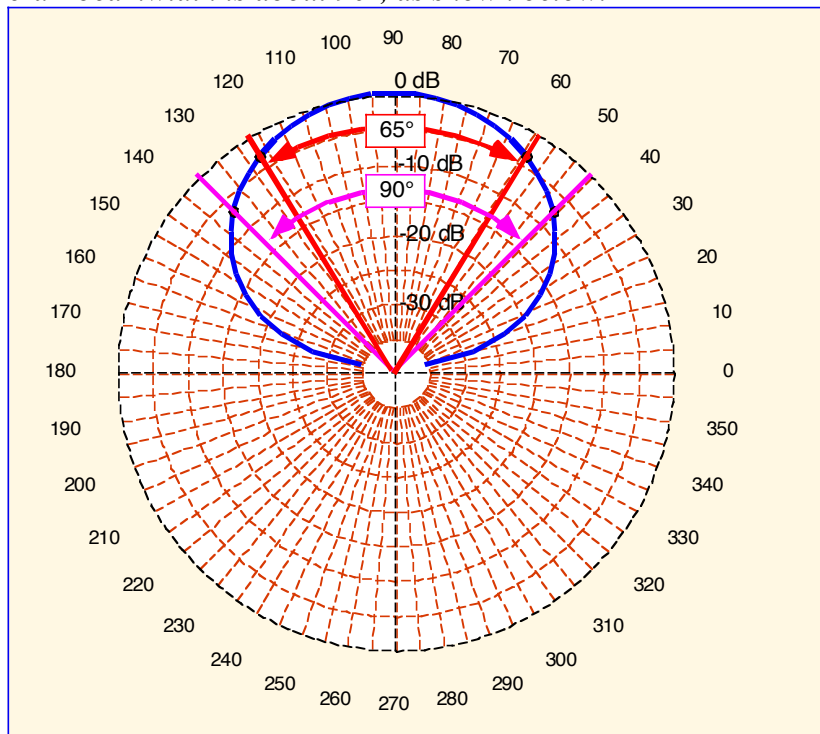

Draw the idealized read zone following the procedure of Figure 6.5, assuming the range in the center of the beam is 4 meters, for a vertically-polarized antenna spaced 1.5 meters from the center of a conveyor, illuminating vertically-oriented tags.

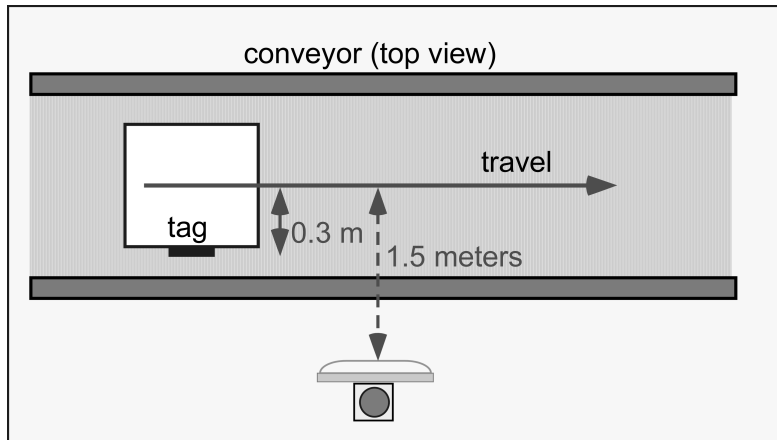

Here's the (approximate) answer:

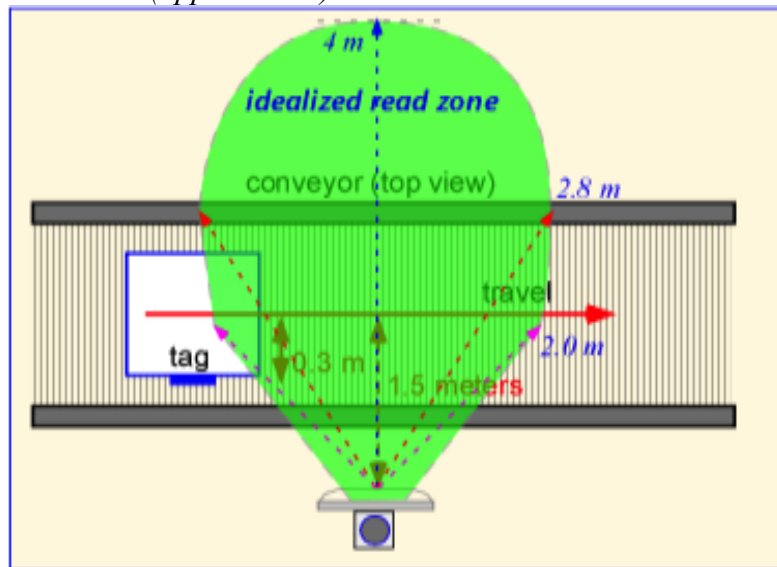

Assume tags are offset towards the antenna by 30 cm relative to the centerline of the conveyor, and that the cartons move along the conveyor at 3 meters/second. How long does a tag spend in the (idealized) read zone?

The edge of the idealized read zone in this region is at an inclination of 45° from beam center, so the distance from the reader antenna to the tag ($1.5 - 0.3 \approx 1.2$ m) is the same as the distance from beam center to the tag. Thus the total distance traveled in the read zone is 2.4 m and the time in the zone is $(2.4/3) = 0.8$ seconds.

Now assume horizontal tags and a horizontally-polarized antenna. The voltage at the tag is reduced by the cosine of the angle of incidence θ .

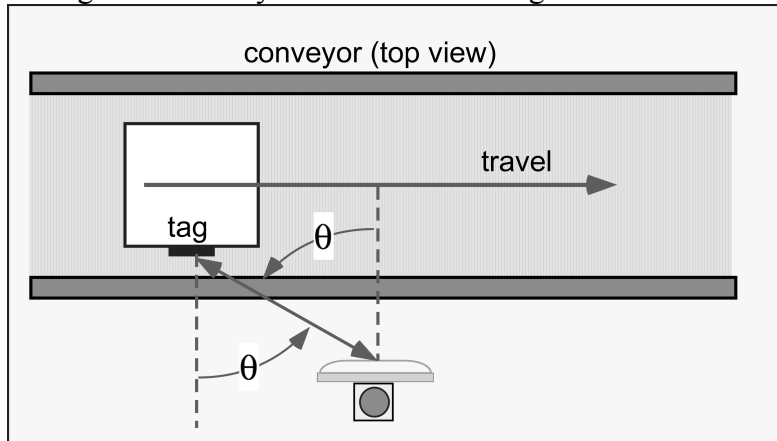

How does the read zone change, assuming that range is proportional to the power (voltage²)? How long does the tag spend in the read zone?

At 45° the voltage would be reduced by a factor of 0.707, or around 3 dB; at 30° the effect is 1.25 dB. The effective beam widths for the same received power are reduced by roughly 20° and 10° for 6-dB and 3-dB respectively, as shown below.

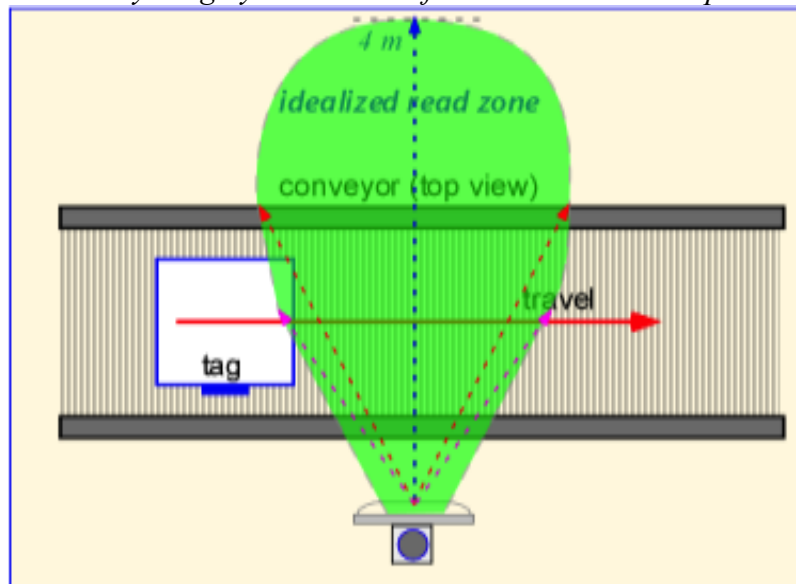

In the idealized-read-zone approximation the time in the read zone is reduced by a factor of $\sin(35^\circ)/\sin(45^\circ) \approx 0.8$, so the time becomes about 0.65 s.

Time in zone:

 0.8 s (vertical polarization)

 0.65 s (horizontal polarization)

Bandwidth:

3. When a dielectric material is placed between the patch and ground plane of a patch antenna, the length and width of the antenna can be reduced as roughly the square root of the dielectric constant, for the same operating frequency:

$$L \rightarrow \frac{L_{old}}{\sqrt{\epsilon}}; \quad W \rightarrow \frac{W_{old}}{\sqrt{\epsilon}}$$

Equation (6.16) becomes

$$\sqrt{\frac{L_{ant}}{C_{ant}}} = Z_{line} \approx \frac{Z_0}{\sqrt{\epsilon}} \frac{d}{W}$$

where ϵ is the relative dielectric constant. Following the derivation used in the absence of a dielectric, show that the antenna capacitance is unchanged from its value for an air-based patch of similar ratio (W/L).

Since the width and length scale as the square root of the dielectric constant, the area scales as $1/\epsilon$. The capacitance, which is proportional to $\epsilon A/d$ in the parallel-plate approximation, thus scales as ϵ/ϵ -- that is, it doesn't change.

Assume that the radiation resistance is linear in the ratio of the wavelength in air to the width. Show that the radiation resistance is increased by the square root of ϵ ; demonstrate that the antenna bandwidth is decreased by the square root of the relative dielectric constant.

Since the wavelength in air doesn't change when the dielectric is added but the width shrinks as $\epsilon^{1/2}$, the radiation resistance goes up as $\epsilon^{1/2}$. Recall that for a patch antenna, the radiation resistance is taken as in parallel with the reactances (Figure 6.11). Therefore the quality factor Q is the product of the reactance and the resistance, so Q also increases as $\epsilon^{1/2}$, and therefore the bandwidth (proportional to $1/Q$) is degraded by the same factor.

Cabling:

4. You need to run cable to four antennas around a doorway. There is no time to trench the concrete floor, so the cabling must be run in conduit above the doorway. The reader, with four monostatic reverse-polarity TNC antenna connections, is mounted in a standard rack fixed 1 meter from the gantry, which is 4 meters across around a 3-meter doorway. The reader's maximum output power is 33 dBm. The setup is shown below:

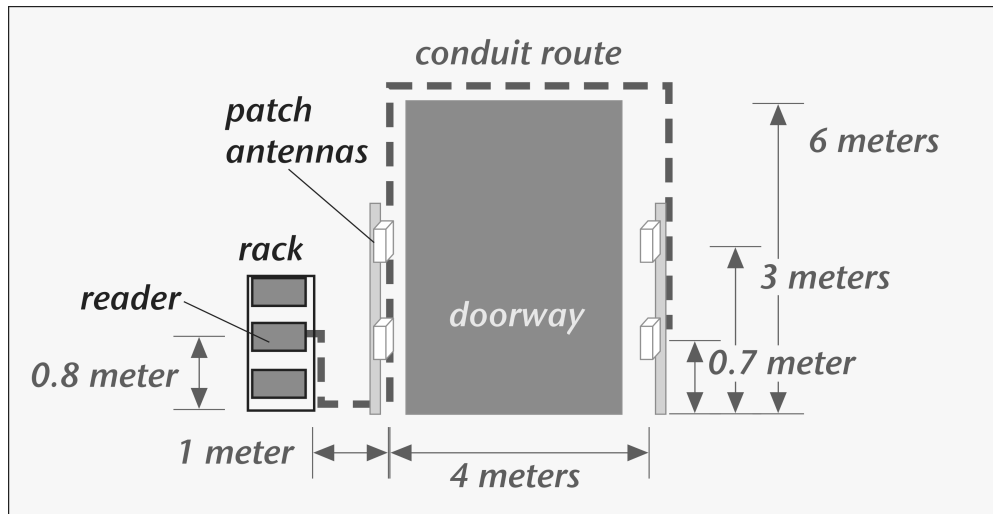

In a cabinet you find two 20-meter and two 6-meter lengths of coaxial cabling terminated in BNC connectors. You measure the outer diameter with a caliper and find it to be 0.2 cm. Estimate the cable loss based on Figure 6.37.

- Should you use this cabling to connect the reader to any or all of the antennas?
From Figure 6.37, a 2-mm-OD cable has loss between .6 and 1.4 dB/m; let's use 1 dB/m as a decent guess. The cable losses are therefore about 20 and 6 dB for the 20- and 6-meter cables. A cable loss of 20 dB is prohibitive. A cable loss of 6 dB is going to cost you a factor of 2 (at least) in range or require 6 dB additional output power (that's a factor of 4!), and the short cable only reaches the near-side antennas. You need better cables.
- If you order replacement cabling, what should the outer diameter be to ensure that 1 watt is delivered to each antenna?
The longest run is about 17 meters, so we need a cable loss less than $3/17 = 0.18$ dB/m. From the figure this requires a cable diameter of around 1 cm.
- Should you remember to check whether the connectors on the antennas are N-male or N-female?
Yes. And of course the other side of the cable needs to terminate in RP-TNC connectors, or you need to purchase N-to-TNC adaptors.
- When you forget to check and purchase cabling terminated in male mini-UHF connectors on both sides, and discover the discrepancy at 11 PM Sunday night for an installation that you promised for 8 AM the following Monday, what do you think the likelihood is that you can find the appropriate adaptors for both sides of each cable in the neighborhood convenience store?

- ___ 1/1000
- ___ 1/1,000,000
- ___ diddly/squat
- ___ exactly zero
- ___ much higher after consuming the six-pack of beer that you did find there

As everyone ought to know, microwave cable adaptors can only appear in convenience stores by quantum mechanical tunneling processes, with a probability so low that a Turing machine couldn't tell if it would ever finish writing the leading zeroes, and Turing machines can't drink – they just punch holes in the beer cans.

You have been warned.

Chapter 7

Matching Antenna and IC:

1. A new tag IC from the Silicon Valley startup company Fundless Networks is reported to consume a DC power of 0.3 microwatts at an input voltage of 0.5 V. Treat the IC load as a simple parallel resistor and find the resistance value:

$$R_p = \underline{0.83 \text{ Meg}} \text{ ohms}$$

$$R = V^2/P \text{ in the DC case.}$$

The input capacitance is 0.5 pF. What are the series equivalent input circuit values at 915 MHz?

$$R_s = \underline{0.15} \text{ ohms} \quad C_s = \underline{0.5} \text{ pF}$$

Recall the formulae are:

$$R_s = \frac{R_p}{1 + (\omega C_p R_p)^2}; \quad C_s = \frac{1 + (\omega C_p R_p)^2}{\omega^2 C_p R_p^2}$$

In this case the resistance is so large that the “1+” parts can be completely ignored.

What is the voltage amplification factor for a conjugate-matched antenna?

$$|V_{IC}/V_{oc}| = \underline{1200}$$

Just plug values into equation (7.10).

Assume the input capacitance was matched using a simple series inductor, and that the antenna looks like a voltage source and radiation resistance matched to the load series resistance. What is the bandwidth of the overall antenna-IC circuit?

$$BW = \underline{0.76} \text{ MHz}$$

$$|X_{ant} + X_{IC}| = 2R_{load} @ \left(|f - f_{ctr}| = \frac{BW}{2} \right)$$

What is the voltage multiplication factor at the band edge at 902 MHz?

$$|V_{IC}/V_{oc}| = \underline{\quad 35 \quad}$$

At the band edge, the total reactance is about $X_L - X_C = j343 - j353 = -j10$ ohms. The current is thus reduced by a factor of about $(10/3) = 33$. Thus the multiplication factor at match is reduced by a factor of about 33 (with a tiny correction for the change in the capacitive reactance). It still seems like we have a lot of voltage multiplication, but if the tag were designed to operate at band center (1200 times) it won't work at all at band edge (33 times less voltage).

2. After sitting through three hours of PowerPointless slides and a lunch whose fat content is measured in ounces rather than grams, Bob the lazy RF designer snags a prototype IC from Fundless' VP of Sales, Sal E. Closer. Being Bob, he doesn't want to design a matched antenna and instead simply attaches the IC to the 915-MHz resonant dipole antenna he took from Amy's desk (see Figure 7.9) What is the power transfer coefficient?

$$\tau = \underline{\quad 0.03\% \quad} \text{ at } 900 \text{ MHz}$$

Since the dipole is resonant (and a resonant dipole is reasonably broadband – it doesn't change much at 900 MHz) it just looks like a voltage source and resistance; at this frequency the resistance is around 65 ohms. So the total impedance is the 65 ohm resistor in series with the 0.5 pF capacitor, and the power transfer coefficient is obtained from equation (7.8) using 0.15 ohm as the load resistance.

Should this be Bob's raise at his next performance review?
Why exactly is he getting a raise?

3. Consider the matching problem shown below. What shunt inductance is required to move the impedance from point 2 to point 3, assuming a frequency of 915 MHz?

$$\text{inductance} = \underline{\quad 9.1 \quad} \text{ nH}$$

The change in the imaginary part of the conductance Y is $(0.008 - (-0.011)) = -0.019$. This is the susceptance $1/j\omega L$ of the shunt inductor, implying an inductor of about 9 nH.

Assume the inductance of a straight conductive line is

$$\ell(nH) = 2L \left(\ln \left(\frac{4L}{w} \right) - 1 \right)$$

where L is the length of the line in cm and w is the width of the line. If the lines used in the tag antenna are .2 mm wide, how long is the shunt inductor?

length = 1.0 cm

Repeat the exercise for the series inductor, remembering that the physical implementation will split this into two series inductors with the IC between them:

inductance = 46 nH length = 2.2 cm (for each of the two)
 The required reactance is $348 - 86 = 262$ ohms, requiring two 2.2 cm inductors.

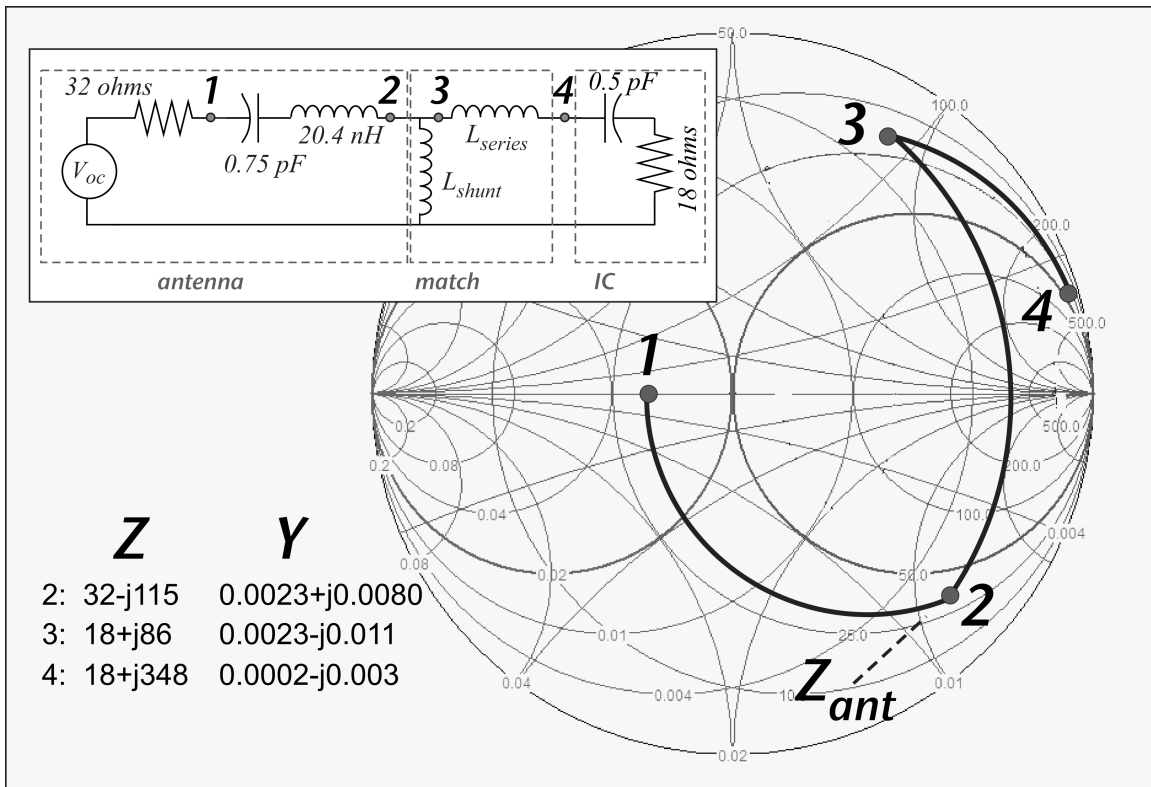

Radar Scattering Cross-Section

4. A tag is placed in an anechoic (reflection-free) chamber, 1.25 meters from a linearly-polarized test antenna with a gain of 4 at 915 MHz. The transmitted signal is 10 dBm. The measured reflected signal, corrected for antenna reflections, is -50 dBm. What is the radar cross-section of the tag?

$$\text{RCS} = \underline{28} \text{ cm}^2$$

The power delivered to a unit area at a distance r is $G_a/4\pi r^2$. This power is presumed to be re-radiated isotropically. The relative amount of power received by the transmit antenna is then $G_a A_e/4\pi r^2$, where the effective aperture of an isotropic antenna is $\lambda^2/4\pi$; the actual received power is thus proportional to the radar scattering cross-sectional area. Putting it all together and solving for RCS we have:

$$\text{RCS} = \left(\frac{\Gamma_1^2}{G_a^2} \right) \frac{(4\pi)^3}{\lambda^2} r^4$$

The reflection coefficient Γ corresponding to a return loss of 60 dB is 0.001; the wavelength is 0.33 m, and $G_a=4$, so we plug in to find $\text{RCS}=28 \text{ cm}^2$.

Metal Surfaces

5. The tag of problem (3) is to be used mounted on the bottom of a metal car body using a 5-mm-thick foam spacer. Near the metal surface, the series model of the antenna becomes 1.5 pF and 10 nH in series with 1 ohm. The open-circuit voltage is reduced from its value in the open by $2 \sin(2\pi(0.5/8.2)) = 0.19$. Ignore any change in the matching inductors and calculate the value of the voltage presented to the IC, presuming that 1 V was present for the same antenna illumination with the tag in the open.

$$V(\text{IC}) = \underline{0.19} \text{ V}$$

The combination of matching circuit and IC used to be a conjugate match, so it must have looked like $32+j115$ ohms. The total impedance seen by the voltage source was then 64 ohms since the reactance of matched IC should cancel that of the antenna at the matched condition.

Since we are ignoring changes in the match elements, the new total impedance is about $33+j56.5$ (the capacitance of the antenna got larger so it contributes less reactance; the circuit now looks inductive). The total impedance is around 65.4 ohms – not much changed from what it was before! Since the open-circuit voltage is reduced by 0.19, the current flowing in the circuit is similarly reduced, and the

voltage across the IC will be 0.19 V. That is, the biggest effect of the metal is the reduction in the electric field.

What is the power transfer coefficient?

$$\tau = \underline{\quad 3\% \quad}$$

Just plug the impedance and resistance values into equation (7.8).

If the tag needs 0.5 V to turn on, how will the read range be affected?

Again the same factor 0.19 will impact the range when it is voltage-limited and the matching structure is fixed.

6. Derivation of Series-Parallel Transformation: Imagine we have a load (like our integrated circuit) connected through a T-match that we model as a shunt impedance Z_{sh} followed by a series impedance Z_{ser} . Can we find values Z_{shtr} and Z_{sertr} , and perhaps a transformed load Z_{Ltr} , such that, looking from the left, the series-shunt and shunt-series arrangements present the same impedance, no matter what the load is?

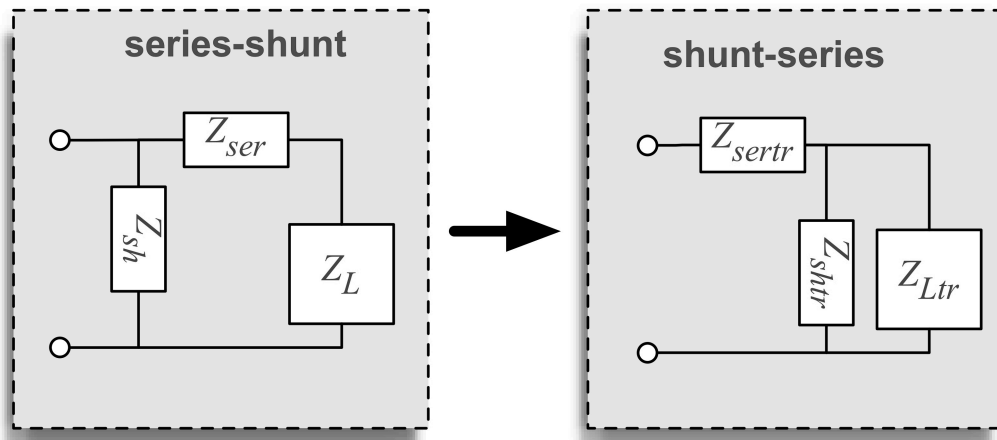

If this can be done, it has to work for the two limiting loads: an open circuit and a short circuit ($Z_L = 0$ and ∞). Using the formulas for series and parallel impedances (Appendix 3), we can show:

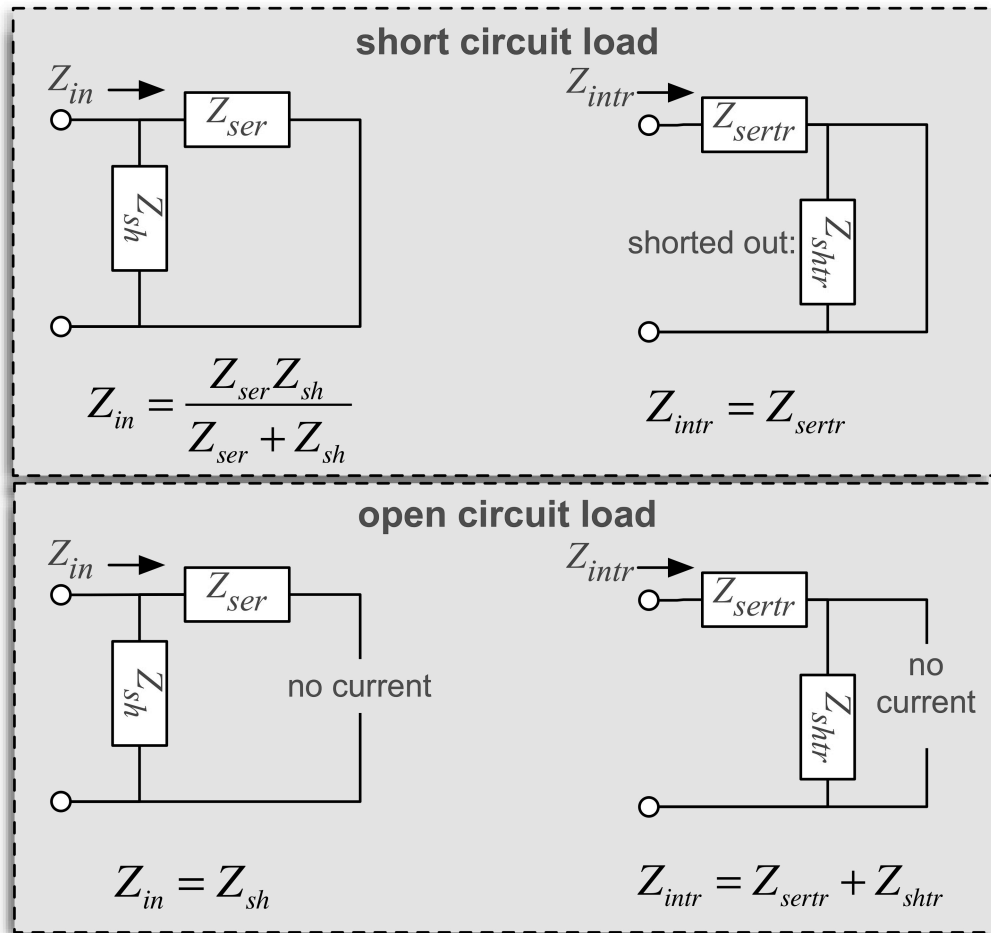

Now we require that the transformed versions are equal to the non-transformed versions in both cases:

$$Z_{sertr} = \frac{Z_{ser} Z_{sh}}{Z_{ser} + Z_{sh}}; \quad Z_{sh} = Z_{sertr} + Z_{shtr}$$

Show that the transformed shunt impedance is:

$$Z_{shtr} = \frac{(Z_{sh})^2}{Z_{ser} + Z_{sh}}$$

First we substitute for Z_{sertr} in the second equation above, getting:

$$Z_{sh} = \frac{Z_{ser} Z_{sh}}{Z_{ser} + Z_{sh}} + Z_{shtr}$$

Multiply out the denominator on both sides to obtain:

$$Z_{sh}^2 + Z_{ser} Z_{sh} = Z_{shtr} (Z_{ser} + Z_{sh}) + Z_{ser} Z_{sh}$$

and then solve for Z_{shtr} :

$$Z_{shtr} = \frac{Z_{sh}^2}{Z_{ser} + Z_{sh}}$$

Note that these can both be written in a similar fashion as:

$$Z_{shtr} = \beta Z_{sh}; \quad Z_{sertr} = \beta Z_{ser}; \quad \beta \equiv \frac{Z_{sh}}{Z_{ser} + Z_{sh}}$$

Using this fact, we can write the statement that the impedance is the same for ANY load as:

$$\frac{Z_{sh} (Z_{ser} + Z_L)}{Z_{sh} + Z_{ser} + Z_L} = Z_{sertr} + \frac{Z_{shtr} Z_{Ltr}}{Z_{shtr} + Z_{Ltr}} \rightarrow$$

$$\frac{Z_{sh} (Z_{ser} + Z_L)}{Z_{sh} + Z_{ser} + Z_L} = \beta Z_{ser} + \frac{\beta Z_{sh} Z_{Ltr}}{\beta Z_{sh} + Z_{Ltr}}$$

Now comes the hard part: SHOW that this equation is always true if:

$$Z_{Ltr} = \beta^2 Z_L$$

It may be very helpful to note that:

$$\beta Z_L + Z_{sh} = \beta (Z_L + Z_{ser} + Z_{sh})$$

Be patient, this is a mess, but it can be done. First substitute for the transformed load resistance:

$$\frac{Z_{sh} (Z_{ser} + Z_L)}{Z_{sh} + Z_{ser} + Z_L} = \frac{\beta^3 Z_L Z_{sh}}{\beta^2 Z_L + \beta Z_{sh}} + \beta Z_{ser}$$

which can obviously be simplified to:

$$\frac{Z_{sh} (Z_{ser} + Z_L)}{Z_{sh} + Z_{ser} + Z_L} = \frac{\beta^2 Z_L Z_{sh}}{\beta Z_L + Z_{sh}} + \beta Z_{ser}$$

Now use the trick noted above to obtain:

$$\frac{Z_{sh} (Z_{ser} + Z_L)}{Z_{sh} + Z_{ser} + Z_L} = \frac{\beta Z_L Z_{sh}}{Z_L + Z_{ser} + Z_{sh}} + \beta Z_{ser}$$

Putting the last term over the common denominator, we can thus multiply the denominator away to get:

$$Z_L Z_{sh} + Z_{ser} Z_{sh} = (\beta Z_{ser}^2 + \beta Z_L Z_{ser} + \beta Z_{ser} Z_{sh}) + \beta Z_L Z_{sh}$$

or

$$Z_L Z_{sh} + Z_{ser} Z_{sh} = \beta (Z_{ser} [Z_L + Z_{sh}] + Z_{ser}^2 + Z_L Z_{sh})$$

Substitute for β and multiply out:

$$Z_L Z_{sh} + Z_{ser} Z_{sh} = \frac{Z_{sh} (Z_{ser} [Z_L + Z_{sh}] + Z_{ser}^2 + Z_L Z_{sh})}{Z_{ser} + Z_{sh}}$$

$$(Z_{ser} + Z_{sh}) (Z_L Z_{sh} + Z_{ser} Z_{sh}) = Z_{sh} (Z_{ser} [Z_L + Z_{sh}] + Z_{ser}^2 + Z_L Z_{sh})$$

$Z_L Z_{sh}^2 + Z_{ser} Z_{sh}^2 + Z_{ser}^2 Z_{sh} + Z_L Z_{ser} Z_{sh} = Z_L Z_{sh}^2 + Z_{ser} Z_{sh}^2 + Z_{ser}^2 Z_{sh} + Z_L Z_{ser} Z_{sh}$
and then just start cancelling:

$$Z_{ser} Z_{sh}^2 + Z_{ser}^2 Z_{sh} + Z_L Z_{ser} Z_{sh} = Z_{ser} Z_{sh}^2 + Z_{ser}^2 Z_{sh} + Z_L Z_{ser} Z_{sh}$$

$$Z_{ser}^2 Z_{sh} + Z_L Z_{ser} Z_{sh} = Z_{ser}^2 Z_{sh} + Z_L Z_{ser} Z_{sh}$$

$$Z_L Z_{ser} Z_{sh} = Z_L Z_{ser} Z_{sh}$$

$$0 = 0$$

This derivation used the Mac app LiveMath Maker, a descendent of the amazing Theorist of the 80's, which is a really nifty bit of software but with pretty lame handling of subscripts. Sorry.

Chapter 8

Packet structures and Medium Access Control:

1. The International Organization for Contention's (IOC) STAR (Slothful-Tag-And-Reader) Protocol requires that the tag transmit fifty '0' bits and a twelve-symbol preamble prior to sending its 96-bit identification code. A parity check bit is embedded after each 8-bit byte of the ID code. The ID code is followed by a 16-bit CRC. What percentage of the tag message is devoted to formatting and error checking instead of sending data?

48 %

90 of the 186 bits in a packet are devoted to formatting and error check.

The IOC is organized into working groups. Working group RPD-1 (Rate Performance Disparagement) has tabled a proposal for providing tags with the option of replying with only the preamble, ID, and CRC, also eliminating the parity check digits. The working group is now stuck, since the British members believe that tabling refers to bringing a measure up for consideration, whereas the American members understand the term to mean that the proposal has been abandoned, the European members are on vacation for 36 weeks, and the Asian members are too busy making products to attend the meetings. Let's help them out. If the reader command causing a tag to reply with its ID requires 48 bits and is transmitted at half the rate of the tag reply, and a four-reader-bit gap is specified between reader command and tag reply and prior to another command, how much can throughput be improved by the tabled proposal?

21 %

Ignoring all other aspects of the exchange, the time taken for a reader command and tag reply was the equivalent of 290 tag bits in the old scheme, and is reduced to 228 tag bits in the new scheme. The difference of 62 bits is 21% of the old total.

In a real case the improvement would be even less: there is probably a gap after the reader reply before a new tag request, and the protocol has somehow to deal with allocating the medium to multiple tags, probably involving additional overhead that would not be affected by the change in tag reply format.

Is this improvement worth calling the European members back from the Mediterranean beaches?

YES _____ NO _____

It's winter, they're in the Alps X

2. To the consternation of visually-impaired² Committee Chair Toulouse Track, all the 124 voting members have shown up at the meeting to vote on whether “tabling” should be interpreted according to the British, American, or Icelandic conventions³. Dr. Track decides to allocate the right to speak based on a slotted Aloha approach. He will ask each participant to choose a random number between 1 and 100 and write it down on the tablet of paper next to their glass of ice water. He will then flip a coin to decide whether to count up from 0 or down from 100, and call out numbers in the resulting sequence for each participant to speak. Each member will then have 1 minute to state their case favoring or opposing the resolution. If no one speaks for 10 seconds after a number is called, Dr. Track will go on to the next number. In the event that two or more members have chosen the same number, they will all speak simultaneously. Dr. Track will record that a collision occurred, draft a memo regretting the fact to be delivered to the IOC Intellectual Property Manager, Pat N. Pending, and go on to the next slot.

What is the likelihood that there will be no collisions?

100% _____ 10% _____ 5% _____ 0% X
There are only 100 slots and 124 members. There would be 24 collisions if slots were distributed uniformly, though there could be as little as 1 collision if all the extra folks happened to fall into one slot.

If there are ten 2-person collisions, three 3-person collisions, and one each with eleven people (the number ‘1’) and nine people (the number ‘100’), how long does it take for Dr. Track to get through all the allocated slots, assuming a 5-second inter-slot gap for Dr. Track to call out the next number?

 95.75 minutes

There are 75 uncollided slots, 15 collisions, and 10 empty slots, so 75 minutes of useful speech occur, plus 2.5 minutes of no speech, 10 minutes of folks talking over each other, and 8.25 minutes of calling the next slot number. Note that the efficiency of this particular exchange is about 78% (75 useful minutes in 96 total).

² One of many consequences of the embarrassing incident involving laser surgical modification of the cornea, a toy caboose, and Miss Cody Pendant from Twelve-Step Temporary Employment Agency.

³ Reputed to involve indecent use of geothermal energy.

Would it have been more efficient to hold the meeting underwater using American Sign Language, or would that choice have a prejudicial impact on the result of deliberations?

YES TO BOTH PROBABLY _____ WHAT? _____

First-Generation Standards:

3. In Singapore, unlicensed RFID operation is allowed in the band 923-925 MHz. Is it possible to choose a 500-kHz channel in this band for reader transmission to ensure that Class 0 tag signals are also in the band?

YES _____ NO X

The tag signals are about 2.2 and 3.3 MHz from the reader signal; no matter where it transmits in the 2-MHz-wide band, some tag signals are out-of-band.

4. A Class 0 reader using a symbol time of 25 microseconds and ID2 to singulate tags is counting tags with 128-bit IDs. How long does it take for the reader to receive a complete tag ID and error check?

3600 microseconds

*The easiest way to do this is to refer to the text (section 3.1): 1400 microseconds are required to get 96 bits using a symbol time of 12.5 microseconds, so to get 128 bits (plus CRC) with a symbol time of 25 microseconds will take $(144/112)*2*1400 = 3600$ microseconds.*

5. A Class 0 reader monitors a conveyor. Tagged boxes on the conveyor are within the read zone for 1 second; on average, boxes are spaced apart by 3 meters and move at 1 meter per second. The reader continuously reads at full speed as in problem 4 above, simply discarding reads whose CRC and ID do not agree, and stopping every 100 milliseconds to issue a **RESET** and calibration sequence for new-entering tags. If the reader 24 hours per day, and assuming no actual metaphysical intervention, how many ghost tags will it detect in a week?

1773 tags

There are lots of ways to answer this question, all producing roughly similar answers and all showing that ghosting is a substantial issue when you make lots of reads. Here's one approach: since the boxes are spaced by 3 meters and move at 1 meter/second, a tag is in the read zone about 1/3 of the time. We make the somewhat arbitrary guess that when a tag is present, the chance of reading a

ghost is reduced – say 10% of the chance when there is no tag – because in general the reader will be reading a valid signal or maybe get a single bit error, and single-bit errors are always corrected by the CRC. (This is just a guess – but it doesn't affect the answer qualitatively. I don't know of anyone who has published detailed data from which we could derive these probabilities.) In one second the reader can read about 274 times (where we have made a tiny correction for the 10 RESET commands issued each second). The reader thus makes about 166 million read attempts a week, or 116 million “equivalent” reads if we correct for the reduced probability of a ghost when a tag is present. If the probability of a ghost tag read occurring when the data is simply random is $1/2^{16}$, that gives us about 1773 ghost reads per week! Even if we were to reduce the box spacing to 1 meter so that there is always a tag present, this would only be reduced to 177 reads/week (and no real system always has tags present during 24x7 operation). To get to <1 ghost/week is not readily achievable in this context.

Of course, the simplest way to reduce this probability is to require two reads of the same tag. Two reads of the same ghost tag within a short time is a seriously improbable occurrence absent a systematic problem in the reader. The cost is that the probability of missing a tag goes up.

6. A Class 1 reader monitors the same conveyor, in Global Scroll mode. To save time, no mask bits are used in the reader command. Production worker Amon Breick carelessly leaves an extra tag on the table close to the reader antenna, so that this tag replies to every **ScrollAllID** command and its backscatter signal is much larger than that of tags on the conveyor. How many conveyor tags will be read under these conditions?

 ≈ 0 %

Recall that if no mask is used, every tag that hears a ScrollAllID command replies with its ID, so the tag next to the antenna will try to reply to every command and nearly always block the weaker signals of distant tags. (Admittedly, every once in a while the nearby tag will suffer a bit error and reject the ScrollAllID command, allowing a brief window for the reply of a more distant tag. The exact probability of this occurrence depends on just where the tag is and in the author's experience varies from one tag to another.)

To avoid catastrophic failure when Amon is not on break, the reader software is modified to issue a **Quiet** command to each tag that is successfully read, so that another tag can participate. If the reader issues a **Quiet** command, with the 96-bit ID of the tag included in the mask, each time it successfully reads a tag, and the remainder of the command (other than the mask bits) takes 1 millisecond to send, what is the impact on the peak read rate? Assume the reader transmits at 60 kbps.

217 reads per second with Quiet vs. 500 reads per second without

Referring to the text and Figure 8.24, we see that the simplest read process without a Quiet command or a Talk command takes roughly 2 msec per exchange (500 tags/second). A Quiet command will require 1 msec + 96/60 = 2.6 msec more, so the new rate is 1000/(4.6) ≈ 217 tags/second.

Gen 2 Protocol:

7. How big does a memory bank have to be before an EBV requires a second byte?

127 words

A single-byte EBV is composed of 7 working bits and 1 extension bit set to 0, so we can represent $2^7 = 128$ possible values.

8. Here is the baseband signal a Gen 2 tag receives. The top shows a closeup of the preamble; the bottom shows the complete command except for the CRC-5 error check bits.

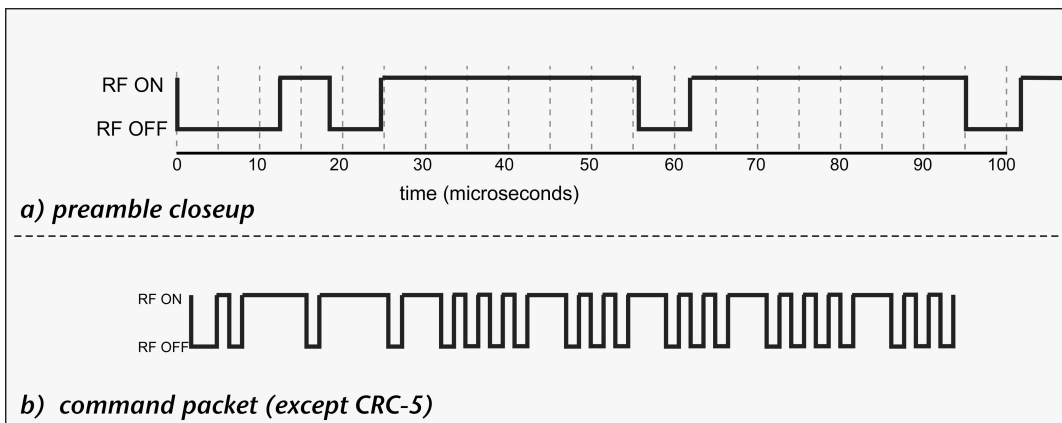

The same image parsed:

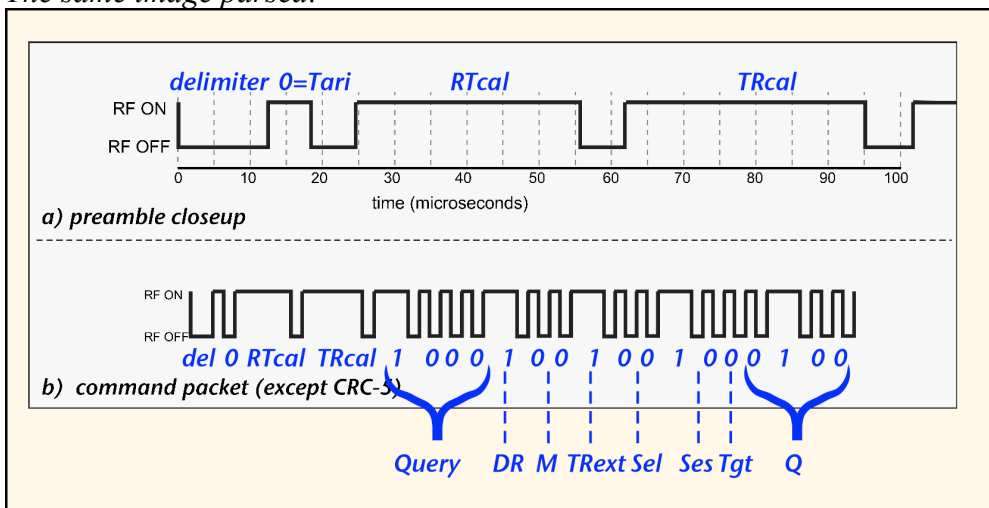

Based on this packet signal:

What is T_{ri} ?

12.5 microseconds

The binary '0' symbol after the delimiter is $25 - 12.5 = 12.5$ microseconds long.

What is the average reader data rate, assuming an equal mix of 1's and 0's?

54,000 bits per second

The duration of T_{cal} is about $(62 - 25) = 37$ microseconds. Since this is the sum of the duration of a binary '0' and a binary '1' symbol, the average symbol time is half of this (18.5 microseconds) if both are equally probable. Thus the data rate is about 54 kbps.

What command is being sent?

Query

You don't really even have to parse this one – the only time we send both T_{cal} and T_{Rcal} is when a new Query is launched. But the command is indeed 1000.

What session flag does the command apply to?

2 (0 to 3)

The session bits are 10 = decimal 2.

What tag backscatter link frequency should be used to respond (estimates are ok)?

What is the tag-to-reader data rate?

BLF: _____ kHz data rate: _____ bits per second

*The divide ratio bit is 1 so the divide ratio is $64/3 \approx 21.3$. The backscatter link frequency is the divide ratio divided by the duration T_{Rcal} , which is about 40 microseconds (that is, roughly $1.1 * T_{cal}$, the smallest allowed value). So the BLF is $21.3/40 \times 10^{-6} = 533$ kHz. The data rate is the same as the BLF because the Miller bits are 00, so $M=1$.*

If this is your reader, and you know that between 1 and 3 tags are in the field of view of the reader at any given time, what is wrong with the parameters of this command?

The Q bits are 0100 = 4, so you've allowed $2^4 = 16$ slots for 3 tags. Not absurd but wasteful: a Q value of 2 would always suffice.

Active Tags

9. If you were a sensing device, would you want to associate with a PAN named Bluetooth? Is Zigbee any better? Shouldn't the IEEE get real about these names?

YES _____

NO, WHY? _____

WHICH QUESTION AM I ANSWERING? _____ X _____

10. Assume a Wi-Fi device sends a packet with 1000 bits in it at 2 Mbps. The radio transmitter produces 10 milliwatts of RF power and is 30% efficient: that is, the RF output is 0.3(DC power in).

How much energy does the transmitter use to actually send the signal?

Each bit takes 0.5 microseconds, so the whole packet takes 0.5 milliseconds. During that time, the transmitter is using 33.3 mW, so the energy required is (33.3/2) microJoules.

_____ 16.7 _____ microJoules

If a 3.7-V AA battery can provide 2000 mA-h, how many packets can be sent before the battery is exhausted, if the above were the only energy needed for operating the node?

*The battery capacity in Joules is $3.7 * 2 * 3600 = 26,640$. Divide by the packet energy above to find the number of packets:*

_____ 1.6×10^9 _____ packets

At one packet per minute, how many years is that?

There are 525,600 minutes in a year, so we get:

_____ 3041 _____ years

Review chapter 5's discussion of an active tag (Figure 5.32 and text). How does the energy usage above compare to the values cited there? What can we conclude

about the actual energy used in data transmission as a fraction of the total energy used by the device?

The discussion in chapter 5 describes a sensor tag that uses about 50 mJ to wake up, get data, establish a communications channel, send the data, and get an acknowledgement. This tag can do about 10 months on a battery, which is rather notably less than the optimistic estimate of 3 millennia. The actual job of sending bits doesn't take very much energy compared to all the other stuff that an active radio system may need to do to decide what data to send and when to send it.

Chapter 8

10. Libraries use RFID for four separate functions:
- associating a book or other item with a user when it is checked out;
 - verifying that all items leaving the library have been properly checked out;
 - noting returned items and allocating them to the proper location for reshelving;
 - performing shelf inventory.

For each of these functions, examine the following questions:

- What read range is needed? What assumptions are you making?
- What environmental conditions is the tag exposed to?
- How many tags must be read at once? This may depend on your checkout model (how many items a user may check out, and how many operations are needed), and interacts with the read range you assumed for inventory.
- What security precautions are required?
- What value is gained relative to a bar code?

There really aren't "right" answers to these questions, but typically a library application is fine with ranges of a few cm for checkout and return, and around 1 meter for anti-theft and inventory. It's often sufficient to read one tag at a time, if you ask the user to put only one book on the checkout surface. Finally, books cost from a few dollars to tens of dollars, but not hundreds or thousands, so tracking needs to be cheap and long-lasting. Therefore passive HF tags are often used, with something like a 96-bit ID.

Then answer the following basic questions:

Type of tag: UHF, HF, or LF? HF

Passive, BAT, or Active? passive

How much memory does the tag need? 12 (bytes)

How are tags packaged and attached?

typically placed on an adhesive plastic sheet and attached to the book's cover or spine

Where are readers to be located?

at checkout stations, exits, return stations, and an inventory cart

11. A semiconductor fabrication facility is a complex place with three floors: a top floor filled with air handling equipment and toxic gas scrubbers, a main floor with semiconductor processing tools and wafer movement and management, and a bottom floor with vacuum pumps, gas supplies, and other support equipment. There are a lot of people involved (as well as a lot of robots), little visibility, and many toxic gases and liquids, as well as high voltages and powerful radio frequency generators. The management would like to be able to locate all the personnel at any time in case of emergency. Two models are under consideration:
- 1: Divide the facility into many small areas with entry by card keys (which are themselves passive 13.56 MHz tags); track location through swipes.
 - 2: Use a personnel badge that can be detected and monitored at any location in the facility.

Examine the same issues as in exercise 1, for each of the two scenarios above:

- What read range is needed? What assumptions are you making?
- What environmental conditions is the tag exposed to?
- How many tags must be read at once?
- What security precautions are required?

Then answer the similar set of basic questions:

Type of tag: UWB, UHF, HF, or LF? _____

Passive, BAT, or Active? _____

How much memory does the tag need? _____ (bytes)

How are tags packaged and attached?

Where are readers to be located?

IF you use a tag with a battery, how are batteries to be monitored and serviced?

As before, there aren't general right answers, but typically we'd find that either approach could work. If you use card keys, the tags are in a credit-card-sized piece of plastic and have on the order of 96 bits (12 bytes) of memory. One tag is read at a time. In order to control entry, it may be

preferable to use an HF tag that implements a secure communications protocol, reducing read range to a few cm – but that's OK for a door entry key. Readers will be placed at every controlled entry in the facility. The down side of this approach is that your ability to find your people is limited by how many partitions there are, so you tend to make a lot of walls and doors that people have to pass through, inconvenient during the work day.

The other approach is to use an active location-supporting tag, such as a WiFi-based tag. In this case, readers are standard or modified WiFi (IEEE 802.11) AP's, probably tucked into the ceilings in several places in each large room. More may be needed in the service bays, where space is constrained and lots of metal objects are around. WiFi supports physical-layer security, e.g. through the Advanced Encryption Standard, but you still have to manage WPA passwords so that only authorized personnel are in your facility.

A battery-powered tag will need to have its battery replaced, probably at intervals of a few months to a year; the tag will probably have an internal battery-state sensor and let you know when replacement is needed. Battery tags are expensive, but so are people.

The battery tag solution requires careful AP placement and surveying to ensure that you can always find all your workers, even in cramped maintenance areas.

In both cases, tags will be packaged as ID-card-like objects to be attached to a worker's clothing or worn around their neck or wrist. Tags need to stand up to ordinary wear and tear but are not exposed to rain, snow, or direct sunlight.

12. Buy some tags and a reader. Plug the reader in and follow the instructions to read a tag. Create a web site describing yourself as an RFID implementation expert. Get an associated Twitter account so you can let everyone know how it worked out.

Did it help that you read the book first? _____ YES _____ NO

Which book?

This one

A good one

A funny one

[X? at least in my dreams...] All of the above